

AMERICAN OUTDOOR GRILL

SIDEBURNER NATURAL OR PROPANE GAS MODEL

INSTALLATION AND OPERATING INSTRUCTIONS



CODE AND SUPPLY REQUIREMENTS: This barbecue must be installed in accordance with local codes and ordinances, or, in the absence of local codes, with either the latest *National Fuel Gas Code (ANSI Z223.1/NFPA 54)*, and *Natural Gas and Propane Storage and Handling Installation Code (CSA-B149.1)*.

This appliance and its individual shutoff valves must be disconnected from the gas supply piping system when testing the system at pressures in excess of $\frac{1}{2}$ psig (3.5 kPa).

This appliance must be isolated from the gas supply piping system by closing its individual manual shutoff valves during any pressure testing of the gas supply system at pressures up to and including $\frac{1}{2}$ psig (3.5 kPa).

All electrical outlets in the vicinity of the barbecue must be properly grounded in accordance with local codes, or, in the absence of local codes, with the *National Electrical Code, ANSI/NFPA 70, or the Canadian Electrical Code, CSA C22.1*, whichever is applicable.

Keep all electrical supply cords and fuel supply hoses away from any heated surface.



SAFETY WARNINGS & CODES

Important: Read these instructions carefully before starting installation.

INSTALLER: Leave these instructions with consumer.

CONSUMER: Retain for future reference.

⚠ WARNING

1. Do not store or use gasoline or other flammable vapors and liquids in the vicinity of this or any other appliance.
2. A propane cylinder not connected for use shall not be stored in the vicinity of this or any other appliance.

⚠ WARNING

Improper installation, adjustment, alteration, service, or maintenance can cause injury or property damage. Refer to this manual. For assistance or additional information consult a qualified professional installer, service agency, or the gas supplier.

⚠ DANGER

IF YOU SMELL GAS:

1. Shut off the gas to the appliance.
2. Extinguish any open flame.
3. Open lid.
4. If odor continues, keep away from the appliance, and immediately call your gas supplier or the fire department.



Certified to: ANSI Z21.58-2007
CSA 1.6-2007

AMERICAN OUTDOOR GRILL

SIDEBURNER MODÈLE NORMAL OU DE PROPANE DE GAZ

INSTALLATION ET CONSIGNES D'UTILISATION



CONDITIONS DE CODE ET D'APPROVISIONNEMENT: Ce barbecue doit être installé selon des codes locaux et des ordonnances, ou, en l'absence des codes locaux, avec l'un ou l'autre le plus défunt code national de gaz de carburant (norme ANSI Z223.1/NFPA 54), et stockage de gaz naturel et de propane et manipulation du code d'installation (CSA-B149.1).

Cet appareil et ses différents robinets d'isolement doivent être disconnected du système sifflant de fourniture de gaz en examinant le système aux pressions au-dessus du ½ psig (kPa 3.5).

Cet appareil doit être isolé dans le système sifflant de fourniture de gaz en fermant ses différents robinets d'isolement manuels pendant tout vérificateur de pression du système de fourniture de gaz aux pressions jusques et y compris le ½ psig (kPa 3.5).

Toutes les sorties électriques à proximité du barbecue doivent être correctement fondues selon des codes locaux, ou, en l'absence des codes locaux, avec le code électrique national, ANSI/NFPA 70, ou le code électrique canadien, CSA C22.1, celui qui s'applique.

Gardez tous les cordes d'alimentation électrique et tuyaux de fourniture en combustible à partir de n'importe quelle surface heated.



AVERTISSEMENTS ET CODES DE SÛRETÉ

Important: Lisez ces instructions soigneusement avant de commencer l'installation.

INSTALLATEUR: Laissez ces instructions avec le consommateur. **CONSUMMATEUR:** Maintenez pour la future référence.

⚠ AVERTISSEMENT

1. Ne stockez pas ou n'employez l'essence ou d'autres vapeurs et liquides inflammables à proximité de ceci ou d'aucun autre appareil.
2. Un cylindre de propane non relié pour l'usage ne sera stocké à proximité de ceci ou d'aucun autre appareil.

⚠ AVERTISSEMENT

L'installation, l'ajustement, le changement, le service, ou l'entretien inexact peuvent causer des dommages ou des dégâts matériels. Référez-vous à ce manuel. Pour l'aide ou les informations supplémentaires consultez un installateur professionnel qualifié, l'agence de service, ou le fournisseur de gaz.

⚠ DANGER

SI VOUS SENTEZ LE GAZ:

1. Coupez le gaz à l'appareil.
2. Éteignez-vous n'importe quelle flamme nue.
3. Ouvrez le couvercle.
4. Si l'odeur continue, gardez à partir de l'appareil, et appelez immédiatement votre fournisseur de gaz ou les corps de sapeurs-pompiers.



Certifié à la norme:
ANSI Z21.58-2007
CSA 1.6-2007

TABLE OF CONTENTS

1	SAFETY WARNINGS & CODES
3	TABLE OF CONTENTS
3	PRODUCT DATA TABLE
4	PARTS LIST
5	PREPARING FOR INSTALLATION
5	INSTALLATION
7	SAFE USE & MAINTENANCE OF PROPANE GAS CYLINDERS
8	CHECKING/CONVERTING THE BURNER ORIFICES
8	SAFETY INFORMATION
9	LIGHTING (IGNITION) INSTRUCTIONS
9	ELECTRONIC LIGHTING
9	MANUAL LIGHTING
9	ELECTRONIC LIGHTING
9	MANUAL LIGHTING
11	REPLACING THE IGNITOR BATTERY
11	TROUBLESHOOTING
12	AMERICAN OUTDOOR GRILL LIMITED WARRANTY

PRODUCT DATA TABLE

Counter opening depth	6" (15.2 cm.)
Counter opening width	8 3/4" (21 cm.)
Counter opening length	14 1/4" (35.8 cm.)
Sideburner BTU	15,000 (4.4 kw.)
Natural gas orifice	#49 (1.854 mm.)
Propane gas orifice	#56 (1.181 mm.)

Table 1 - Product data table

PARTS LIST

Item	Part #	Description
1.	3283-06	Handle
2.	3280-04	Lid
3.	3275-10	Burner grid
4.	3280-1010	Housing
5.	3275-39	Valve manifold assembly
6.	3020	Valve knob
7.	3275-32	Burner assembly
8.	3275-36	Burner cap
9.	3275-49-1	Burner orifice for natural or propane
	3275-56-1	Gas (see Product Data Table, Table 1, for size information)
10.	3199-32	Ignitor and wires

Replacement parts can be ordered from your local dealer.

IMPORTANT
This sideburner is fully pre-assembled and tested at the factory.

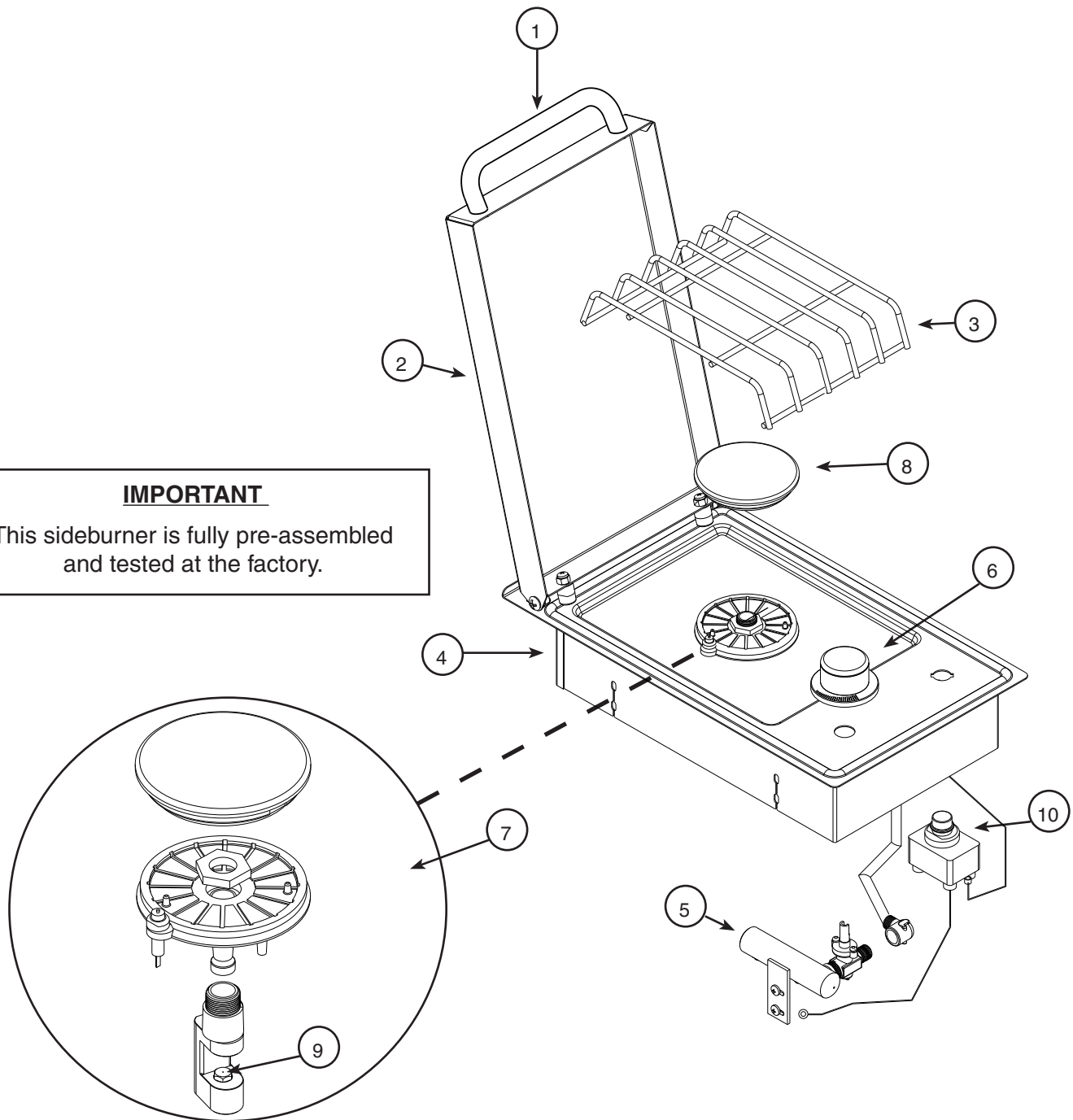

PREPARING FOR INSTALLATION

Your sideburner is designed to complement your gas barbecue. It provides a convenient, efficient cooking surface for side dishes that require bottom heat only.

TOOLS REQUIRED: A pair of adjustable wrenches, pliers, or vice grips for the gas connection.

CODE AND SUPPLY REQUIREMENTS: This burner must be installed in accordance with local codes and ordinances, or, in the absence of local codes, with the National Fuel Gas Code, ANSI Z223.1.

This appliance and its individual shutoff valve must be disconnected from the gas supply piping system when testing the system at pressures in excess of $1/2$ psig (3.5 kPa).

The appliance must be isolated from the gas supply piping system by closing its individual manual shutoff valve during any pressure testing of the gas supply system at pressures up to and including $1/2$ psig (3.5 kPa).

WHERE TO INSTALL YOUR SIDEBURNER

Sideburners are designed for outdoor use only.

WARNING

Sideburners must be installed in masonry or other type of fireproof enclosure. The unit is not insulated and therefore must be installed with 18" (45.7 cm) of side and back clearance from unprotected combustible materials such as wood, plastic, or stucco with wood framing. Do not install under overhead unprotected flammable construction. A 4" (10.2 cm) clearance to any back wall is required to open the lid properly.

This is a drop-in type unit. The unit must be removable for gas hookup, servicing, and burner adjustment.

PROPER VENTILATION: Proper ventilation of your sideburner must be maintained to ensure proper performance. **Do not operate with the lid closed.**

GAS SUPPLY PLUMBING REQUIREMENTS: Rigid $1/2$ " (1.3 cm) black steel pipe is required to conduct the gas supply into the masonry opening for connection to the unit. Apply pipe joint compound (resistant to all gasses) to all male pipe fittings and tighten all joints securely. Do not use pipe joint compound to connect flare fittings. The pipe should enter the enclosure either from the bottom or from any side at least 4" (10.2 cm) below the countertop (see Fig. 5-1).

Note: Any protrusion into the enclosure higher than 6" (15.2 cm) below the countertop will obstruct the frame and prevent the unit from dropping into place.

Note: An external valve (with a removable key) in the gas line is recommended for safety.

GAS SUPPLY AND MANIFOLD PRESSURES: For **natural gas** - normal 7" (17.8 cm) water column (w.c.), minimum 5" (12.7 cm), maximum $10\text{-}1/2$ " (25.4 cm). For **propane gas** - normal 11" (27.9 cm) w.c., minimum 8" (20.3 cm), maximum 13" (33 cm). A **REGULATOR MUST BE PROVIDED AT THE BOTTLE OR GAS SOURCE FOR USE WITH PROPANE GAS.**

Important: See page 7 for the proper venting of the enclosure.

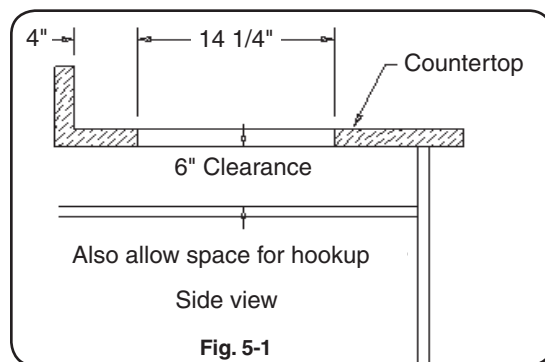

INSTALLATION

CONNECTING THE GAS SUPPLY TO THE SIDEBURNER

1. The burner manifold has a $1/2$ " (1.3 cm) male flare fitting gas inlet elbow. A $1/2$ " female flare fitting connector nut is required to hook the gas supply to the burner.
2. Use a stainless steel flex connector to bring the gas supply from the gas line stub or propane gas tank to the side burner manifold. A $1/2$ " x 24" or 36" flex connector is suitable for most installations.

CAUTION: Use only a C.S.A. listed stainless steel flex connector. Do not use a rubber hose or plastic hose within the enclosure for your sideburner, it will leak, resulting in an explosion and/or serious injury.

3. Be sure the gas supply is off. Connect the pipe adapter fitting supplied with the flex connector to

the gas supply stub. Use pipe joint compound that is resistant to all gasses on the pipe fitting. Tighten fitting to the gas supply and connector flare nut securely.

- Note:** Pipe joint compound must not be used on flare fittings.
4. Connect the flex connector flare nut to the sideburner manifold elbow flare fitting. Be sure to tighten securely. Use a second wrench to support the manifold to avoid damaging the manifold.
 5. Carefully turn on the gas supply and leak test at all connections with a soapy water solution (equal parts liquid detergent and water). If bubbles appear, a leak is present. Turn off gas and tighten connections, turn on gas and repeat leak test. Repeat until no leaks are detected. **Never use a flame to test for leaks.**
 6. Lower the unit into the enclosure.

UTILISATION SÛRE ET ENTRETIEN DES CYLINDRES DE GAZ DE PROPANE

IMPORTANT POUR VOTRE SÛRETÉ

LISEZ ET SUIVEZ TOUS LES AVERTISSEMENTS ÉQUIPÉS DE VOTRE CYLINDRE DE GAZ DE PROPANE.

En actionnant cet appareil avec un cylindre de gaz de propane ON DOIT observer ces instructions et avertissements.

LE MANQUE DE FAIRE AINSI PEUT AVOIR COMME CONSÉQUENCE UNE INCENDIE OU UNE EXPLOSION SÉRIEUSE.

CYLINDRE ET CONDITIONS ET CARACTÉRISTIQUES DE CONNECTEUR

- Des cylindres et les valves de gaz de propane doivent être maintenus en bon état et doivent être remplacés s'il y a des dommages évidents au cylindre ou à la valve.
- Ce gril, une fois utilisé avec un cylindre, devrait être relié à un gallon de la norme 5 (20lb.) cylindre de gaz de propane équipé d'un OPD (remplissez au-dessus du niveau le dispositif d'empêchement). L'OPD a été exigé sur tous les cylindres vendus depuis octobre 1.1998 pour empêcher le remplissage excessif.
- Les dimensions de cylindre devraient être approximativement 12" (30.5cm) de diamètre et 18" (45.7cm) hauts. Des cylindres doivent être construits et marqués selon les caractéristiques pour des cylindres de gaz de propane du département des ETATS-UNIS du transport (D.O.T.) ou le niveau national du Canada, du CAN/CSA-B339, des cylindres, des sphères et des tubes pour le transport des marchandises dangereuses.
- Le cylindre doit inclure un collier pour protéger la valve de cylindre et le circuit d'alimentation de cylindre doit être assuré le retrait de vapeur.
- Le régulateur de pression et l'ensemble de tuyau utilisé doivent assortir les spécifications pour le type I par ANSI Z 21.58-2005/CGA 1.6-2005 (voir la fig. 6-1).
- La valve de cylindre de gaz de propane doit être équipée d'un dispositif d'accouplement de raccordement de cylindre, décrit comme type I dans la norme définie dans le e. de paragraphe ci-dessus. Ce dispositif est généralement décrit comme coupleur rapide de fil de point culminant.
- Si votre cylindre de gaz de propane vient avec une prise de la poussière, placez le bouchon anti-poussière sur la sortie de valve de cylindre toutes les fois que le cylindre n'est pas en service.

OPÉRATION DE COUPLEUR RAPIDE

Pour relier le régulateur/hose à l'ajustage de précision de valve de cylindre de gaz de propane: Serrez l'écrou de main sur le régulateur au-dessus de l'ajustage de précision de fil de point culminant sur la valve de cylindre. Tournez l'écrou de

main dans le sens des aiguilles d'une montre pour engager les fils et pour serrer jusqu'à ce que douillettement. L'utilisation des pinces ou de la clé ne devrait pas être nécessaire. Seulement le propane marqué par cylindres doit être employé.

Pour débrancher: Tournez l'écrou de main dans le sens contraire des aiguilles d'une montre jusqu'à isolé (fig. 6-1).

Important: Avant d'employer le gril, et ensuite chaque fois que le cylindre est enlevé et rattaché, examinez tous les raccordements pour déceler les fuites. Arrêtez les valves de gril et ouvrez la valve principale de cylindre, puis vérifiez les raccordements avec de l'eau savonneuse. Réparez toutes les fuites avant d'allumer le gril.

ATTENTION: Tournez toujours la valve principale de cylindre de propane au loin après chaque utilisation, et avant de déplacer le gril et le cylindre, ou débrancher l'accouplement. Cette valve doit rester fermée et le cylindre a débranché alors que l'appareil n'est pas en service, quoique l'écoulement de gaz soit arrêté par un dispositif de sûreté quand le coupleur est débranché.

Inspectez soigneusement l'ensemble de tuyau chaque fois avant que le gaz soit allumé. Un tuyau criqué ou frangé devrait être remplacé immédiatement.

Si l'appareil est stocké à l'intérieur, le cylindre doit être disconnected et a enlevé. Des cylindres Disconnected doivent être stockés dehors, hors de la portée des enfants, avec les prises de valve filettées étroitement installées, et ne doivent pas être stockés dans un bâtiment, le garage, ou n'importe quel autre secteur inclus.

POUR VOTRE SÛRETÉ

- Ne stockez pas un cylindre de gaz disponible de propane dessous ou ne vous approchez pas de cet appareil.
- Ne remplissez jamais cylindre au delà de 80 pour cent de plein.
- SI L'INFORMATION DANS "A" ET "B" N'EST PAS SUIVIE EXACTEMENT, UN FEU CAUSANT LA MORT OU DES DOMMAGES SÉRIEUX PEUT SE PRODUIRE.

Fig. 6-1 type coupleur rapide de fil de point culminant d'I

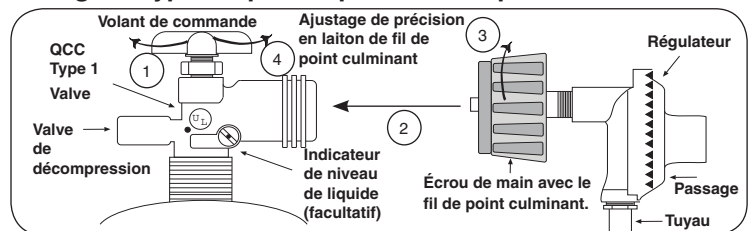

CONDITIONS DE CLÔTURE

POUR VOTRE SÛRETÉ, vous devez fournir les ouvertures suivantes ci-dessous pour le drainage, l'air de recharge, et la ventilation en travers de n'importe quelle zone de stockage exposée à la fuite possible des raccordements de gaz, du gril, ou du cylindre de propane:

Un côté de la clôture de cylindre de gaz a laissé complètement ouvert de extérieur OU en fournissant quatre (4) ouvertures de ventilation. Deux ouvertures doivent être au niveau de valve de cylindre (approximativement 16" (40.6 centimètres) au-dessus du plancher) et sur les murs opposés de la clôture. Deux ouvertures supplémentaires doivent être au niveau de plancher des côtés opposés de la clôture. Les ouvertures de niveau de plancher doivent commencer au plancher et se prolongeront pas plus haut que 5" (12.7 centimètre) au-dessus du plancher. Chaque ouverture doit avoir un minimum de 10 pouces carrés (64.5 cm²) du secteur libre. Pour réaliser la ventilation appropriée, vous pouvez forer une série de trous, omettez le coulis des joints de maçonnerie, ou remplacez une brique avec un écran de tissu de matériel. Si le plancher dans le coffret est augmenté et l'espace sous le coffret est ouvert d'extérieur, les ouvertures inférieures de ventilation peuvent être dans le plancher.

SAFE USE & MAINTENANCE OF PROPANE GAS CYLINDERS

IMPORTANT FOR YOUR SAFETY

READ AND FOLLOW ALL WARNINGS PROVIDED WITH THE PROPANE-GAS CYLINDER.

When operating this appliance with a propane-gas cylinder, these instructions and warnings **MUST** be observed.

FAILURE TO DO SO MAY RESULT IN A SERIOUS FIRE OR EXPLOSION.

CYLINDER/CONNECTOR REQUIREMENTS

- Propane-gas cylinders, valves, and hoses must be maintained in good condition and must be replaced if there is visible damage to either the cylinder or valve. If the hose is cut or shows excessive abrasion or wear, it must be replaced before using the gas appliance (see e.).
- This unit, when used with a cylinder, should be connected to a standard 5-gallon (20 lb.) propane-gas cylinder equipped with an OPD (Overfill Prevention Device). The OPD has been required on all cylinders sold since October 1, 1998, to prevent overfilling.
- Cylinder dimensions should be approximately 12" (30.5 cm) in diameter and 18" (45.7 cm) high. Cylinders must be constructed and marked in accordance with the *Specifications for Propane Gas Cylinders of the U.S. Department of Transportation (D.O.T.)* or the National Standard of Canada, *CAN/CSA-B339, Cylinders, Spheres, and Tubes for Transportation of Dangerous Goods*.
- The cylinder used must include a collar to protect the cylinder valve, and the cylinder supply system must be arranged for vapor withdrawal.
- The pressure regulator and hose assembly used must match the specification for Type I by *ANSI Z 21.58-2005/CGA 1.6-2005* (see Fig. 7-1).
- The propane-gas cylinder valve must be equipped with a cylinder connection coupling device, described as Type I in the standard defined in paragraph e. above. This device is commonly described as an Acme thread quick coupler.
- If the propane-gas cylinder comes with a dust plug, place the dust cap on the cylinder valve outlet whenever the cylinder is not in use.

QUICK COUPLER OPERATION

To connect the regulator/hose assembly to the propane-gas cylinder valve fitting: Press the hand nut on the regulator over the Acme thread fitting on the cylinder valve. Turn the hand nut clockwise to engage the threads and tighten until snug.

ENCLOSURE REQUIREMENTS

FOR YOUR SAFETY, you must provide the openings listed below for drainage, replacement air, and cross-ventilation of any storage area exposed to possible leakage from gas connections, the unit, or propane cylinders:

One side of the gas cylinder enclosure left completely open to the outside **OR** by providing four (4) ventilation openings. Two (2) openings are to be at the cylinder valve level (approx. 16" [40.6 cm] above the floor) and on opposite walls of the enclosure. Two (2) more openings must be at the floor level on opposite sides of the enclosure. The floor-level openings must start at the floor and shall extend no higher than 5" (12.7 cm) above the floor. Each opening must have a minimum of 10 sq. in. (64.5 cm²) of free area. To achieve the proper ventilation, you may drill a series of holes, omit the grout from masonry joints, or replace a brick with a hardware cloth screen. If the floor in the cabinet is raised and the space beneath the cabinet is open to the outside, the lower ventilation openings may be in the floor.

Consult your gas supplier for ventilation and regulator requirements when connecting to a household propane supply.

The use of pliers or a wrench should not be necessary. Only cylinders marked "propane" may be used.

To disconnect: Turn the hand nut counterclockwise until detached (Fig. 7-1).

Important: Before using the unit, and after each time the cylinder is removed and reattached, check the hose for wear (see a.) and check all connections for leaks. Turn off the unit valves and open the main cylinder valve, then check connections with soapy water. Repair any leaks before lighting the unit.

CAUTION: Always turn the propane cylinder main valve off after each use, and before moving the unit and cylinder or disconnecting the coupling. This valve must remain closed and the cylinder disconnected while the appliance is not in use, even though the gas flow is stopped by a safety feature when the coupler is disconnected.

Carefully inspect the hose assembly each time before the gas is turned on. A cracked or frayed hose should be replaced immediately.

If the appliance is stored indoors, the cylinder must be disconnected and removed. Disconnected cylinders must be stored outdoors, out of the reach of children, with threaded valve plugs tightly installed, and must not be stored in a building, garage, or any other enclosed area.

FOR YOUR SAFETY

- DO NOT store a spare propane-gas cylinder under or near this appliance.
- NEVER fill the cylinder beyond 80-percent full.
- IF THE INFORMATION IN a. AND b. IS NOT FOLLOWED EXACTLY, A FIRE CAUSING DEATH OR SERIOUS INJURY MAY OCCUR.

Fig. 7-1 Type I Acme thread quick coupler

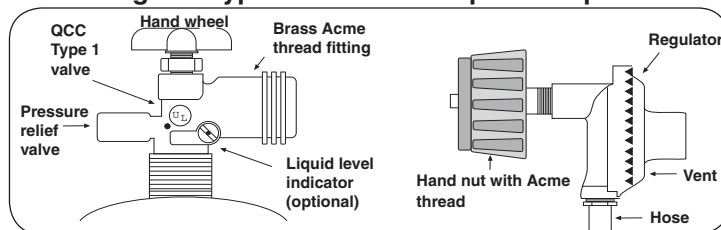

CHECKING/CONVERTING THE BURNER ORIFICES

SIDEBURNER ORIFICE SIZE CHECKING/ CONVERSION (IF EQUIPPED)

Your sideburner has been pre-assembled at the factory.

1. CHECKING FUEL AND PROPER ORIFICES:

This barbecue comes from the factory configured for one type of gas, as marked on the label behind the barbecue face plate. Check the orifice size by lifting the burner cap off the burner, removing the venturi tube, and looking down through the hole in the center (see Fig. 8-1 for the location of the orifice). The drill size is stamped on the orifice. Refer to Table 1 for the correct orifice size for your sideburner.

If you must change the orifice, use a $\frac{5}{16}$ " socket. Unscrew the orifice and replace it with the new one.

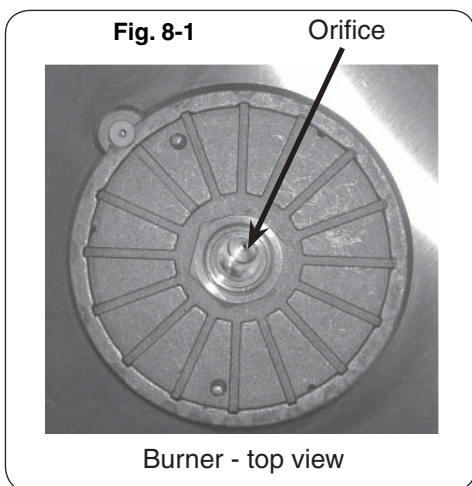

WARNING

HAZARDOUS OVERHEATING WILL OCCUR IF A NATURAL GAS ORIFICE IS USED WITH PROPANE GAS. IF YOU ARE NOT SURE IF THE CORRECT ORIFICES ARE INSTALLED, OR IF AN ORIFICE CHANGE IS NECESSARY, REFER TO THE FOLLOWING INSTRUCTIONS.

2. POSITIONING THE BURNER CAP AND GRILL:

Place the burner cap so it is centered over the burner. Be sure the notches in the burner cap fit over the studs protruding from the burner (Fig. 8-2). The burner cap is coated with a high-temperature porcelain finish. This prevents rust and can be cleaned with oven cleaner.

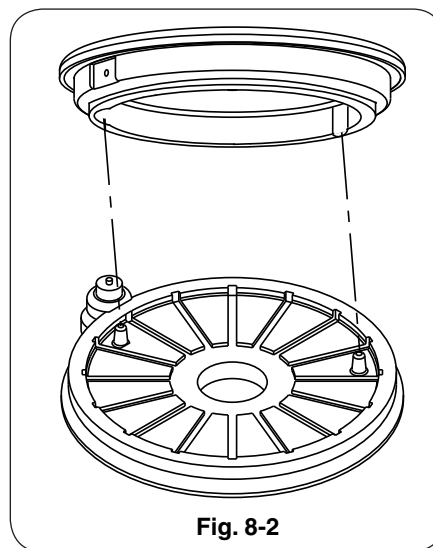

SAFETY INFORMATION

SAFETY TIPS IN USING YOUR SIDEBURNER: Each time you use your sideburner, ensure that:

1. The area around the unit is clear and free from flammable vapors, liquids, and other combustible materials.
2. There is no blockage of air flow around the burner.
3. When using propane gas:
 - a. The special ventilation openings in the enclosure are kept free and clear of debris.
 - b. If connected to a propane cylinder, the rubber hose attached to the regulator is carefully inspected before each use.
 - c. The propane cylinder, regulator, and rubber hose are installed in a location not subject to heating above 125° F (51° C).
4. Burner flames are burning evenly around the burner cap with a steady flame (mostly blue with yellow tipping).

PRESERVING YOUR SIDEBURNER FOR YEARS OF CAREFREE USE: The sideburner surfaces may be cleaned with any common, acid-free, household cleaner.

Occasionally remove the burner cap and, if necessary, use a soft, stiff brush (an old toothbrush) to clean the ports in the burner and the underside of the burner cap.

Important: Never use acid chemicals or abrasive pads to clean porcelain or aluminum surfaces.

Do not operate the burner with the cover closed.

CAUTION: DO NOT ALLOW A COOKING POT OR PAN TO GET TOO CLOSE TO, OR COVER, THE IGNITOR OR FLAME ADJUSTMENT KNOBS DURING USE. IF THIS IS ALLOWED TO HAPPEN OVERHEATING OF THE KNOBS WILL OCCUR, RESULTING IN DAMAGE AND POSSIBLE UNIT MALFUNCTION.

LIGHTING (IGNITION) INSTRUCTIONS

Read entire instructions before lighting, and follow these instructions each time you light the grill.

ELECTRONIC LIGHTING

1. Open all lids and remove all covers from the burners you wish to light.
2. Turn all gas control knobs to their **OFF** positions.
3. Turn on the gas at its source.

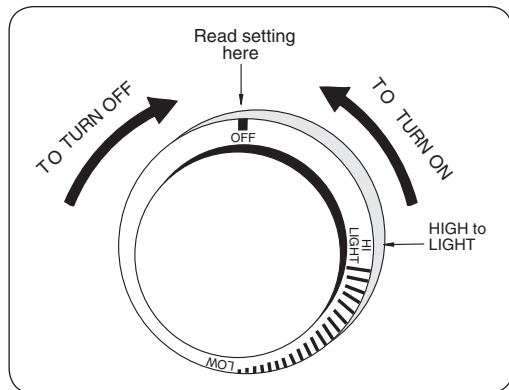

Fig. 9-1 - Valve control knob

MANUAL LIGHTING

CAUTION: Always wait 5 minutes for gas to clear after any unsuccessful lighting attempt.

1. Follow steps 1 through 3 (left).
2. Insert either a burning long-barrel butane lighter, a burning long-stem match, or a burning match held by a wire extension holder (Fig. 9-2) through the cooking grids to the burner (Fig. 9-3). Hold the flame against the edge of the burner.
3. While holding the match or lighter flame next to the burner, depress the appropriate burner control knob and turn it counterclockwise to the **HI LIGHT** position. When the burner lights, remove the lighter

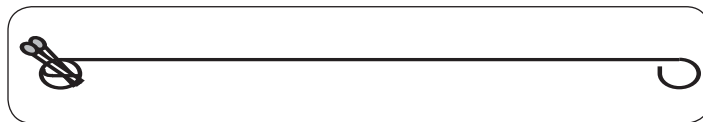

Fig. 9-2 - Match holder

CAUTION: If the burner does not light within 5 seconds, depress the control knob and turn the knob to **OFF**. WAIT 5 MINUTES before repeating step 4. If you smell gas, follow the instructions on the cover of this manual. If the burner still does not light after several attempts, refer to the instructions for MANUAL LIGHTING.

4. Press the ignitor button then depress the control knob for the burner to be lit and turn it to the **HI LIGHT** position. When the burner lights, release the ignitor button.

4. If the burner does not light within 5 seconds, **IMMEDIATELY** depress the knob and turn the burner control knob to **OFF**. WAIT 5 MINUTES before repeating steps 2 through 4 of the MANUAL LIGHTING INSTRUCTIONS.

Note: In some installations, burners achieve a better air/gas mixture and will ignite more quickly if the burner control knob is first turned beyond **HI LIGHT** to **LOW** for lighting.

FOR PROPANE ONLY

Propane tanks are equipped with a safety shut-down device that may cause low or no gas pressure/flame at the burners if operating and lighting instructions are not followed exactly (See important note in the TROUBLESHOOTING section for more details.)

ADJUSTING THE FLAME

The knob on the face of the sideburner control the valve and adjust the flame height. The first labeled position is **OFF**, the second **HI LIGHT**, and the third **LOW**. In between the **HI LIGHT** and **LOW** labels are mid-point marks. Flame height can be set anywhere between the **HI LIGHT** and **LOW** settings.

The height of the flame *with a valve in LOW position* may be further regulated by means of a small adjusting screw in the center of the valve stem. This screw is accessible by removing the valve knob, which pulls straight off the end of the valve stem.

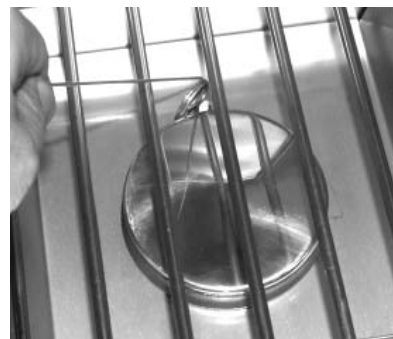

Fig. 9-3 - Manual lighting

REMEMBER: FOR SAFE MANUAL LIGHTING, PLACE A BURNING MATCH OR BUTANE LIGHTER BESIDE THE BURNER - **THEN TURN ON THE GAS** (see Fig. 9-3).

SHUTTING OFF THE SIDEBURNER

To shut off the sideburner, push in the valve control knob and turn it clockwise to the **OFF** position.

Always close the valve from the gas supply after each use of the sideburner.

ALLUMER DES INSTRUCTIONS (D'ALLUMAGE)

Lisez l'instruction entière avant que s'allumant et suivez ces instructions chaque fois vous lumière le barbecue.

ÉCLAIRAGE ÉLECTRONIQUE

1. Ouvrez tous les couvercles et enlevez toutes les couvertures des brûleurs que vous souhaitez vous allumer.
2. Arrêtez tous les boutons de commande de gaz à leurs positions.
3. Allumez le gaz à sa source.

Note: Aucune matière que la méthode d'éclairage vous emploient, n'allument pas le gaz à plus d'un brûleur à la fois. Les brûleurs adjacents de barbecue croix-mettront à feu et l'écoulement de gaz peut être restreint.

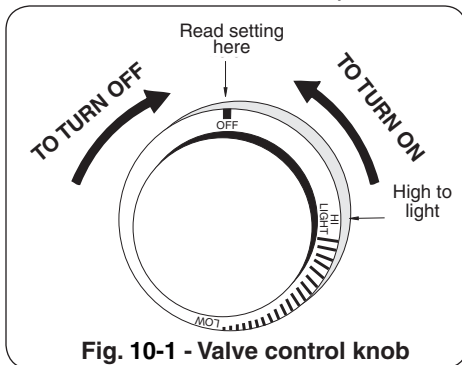

Fig. 10-1 - Valve control knob

ATTENTION: Si les brûleurs ne s'allument pas dans 5 secondes, enfoncez le bouton de commande et tournez le bouton à AU LOIN. ATTENDEZ 5 MINUTES avant de répéter l'étape 5. Si vous sentez le gaz suivez les instructions sur la couverture de ce manuel. Si les brûleurs ne s'allument toujours pas après que plusieurs tentatives, se rapportent aux instructions pour l'ÉCLAIRAGE MANUEL.

4. Enfoncez le bouton de commande pour que le brûleur soit allumé et tournez-le dans la position LÉGÈRE de HI, puis appuyez sur le bouton d'allumage. Une fois que le brûleur s'allume, libérez le bouton d'allumage.
5. Répétez l'étape 4 pour que chaque brûleur additionnel soit s'est allumé.

POUR LE PROPANE SEULEMENT

Les réservoirs de propane sont équipés d'un dispositif d'arrêt de sûreté qui peut ne pas causer le bas ou aucun gaz pression/flame aux brûleurs si le fonctionnement et allumer des instructions ne sont pas suivis exactement (voir la note importante dans la section de dépannage pour plus de détails.)

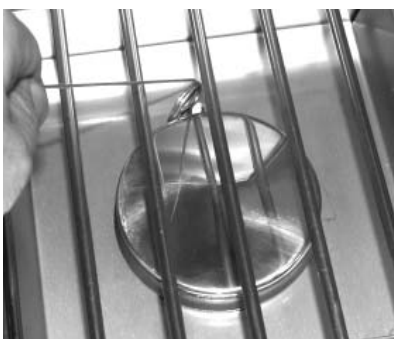

Fig. 10-3 - Éclairage manuel

RAPPEL-VOUS: POUR L'ÉCLAIRAGE MANUEL SÛR, PLACEZ Un ALLUMEUR BRÛLANT D'ALLUMETTE OU De BUTANE PRÈS Du BRÛLEUR - ALLUMEZ ALORS Le GAZ (voyez Fig. 10-3).

Note: Les barbecues dans quelques installations réalisent un meilleur mélange d'air/gas et mettront à feu plus rapidement si le bouton de commande de brûleur est d'abord tourné au delà de la LUMIÈRE de HI au BAS pour l'éclairage.

ÉCLAIRAGE MANUEL

ATTENTION: Attendez toujours 5 minutes le gaz à l'espace libre après que n'importe quelle tentative non réussie d'éclairage.

1. Suivez les étapes 1 à 4 (à gauche).
2. Insérez un allumeur brûlant de butane de long-baril, une allumette brûlante de long-tige, ou une allumette brûlante tenue par un support de prolongation de fil (Fig. 10-2) par les grilles à cuire au brûleur (Fig. 10-3). Pour des backburners, tenez la flamme contre le matériel perforé du brûleur arrière. Pour des sideburners, tenez la flamme contre le brûleur.
3. Tout en tenant l'allumette ou la flamme plus légère à côté du brûleur, enfoncez le bouton de commande approprié de brûleur et tournez-le dans le sens contraire des aiguilles d'une montre dans la position LÉGÈRE de HI. Quand les lumières de brûleur, enlèvent l'allumeur ou s'assortissent.



Fig. 10-2 - Support d'allumette

4. Si le brûleur ne s'allume pas, enfoncez **immédiatement** le bouton et tournez le bouton de commande de brûleur à AU LOIN. ATTENDEZ 5 MINUTES avant de répéter les étapes 2 à 4 des INSTRUCTIONS MANUELLES d'ÉCLAIRAGE.

COUPER LE GRIL

Pour couper le gril, enfoncez chaque bouton de commande de valve et tournez-le dans le sens des aiguilles d'une montre à la position de repos.

Fermez toujours la valve à l'offre de gaz après chaque utilisation du barbecue.

REPLACING THE IGNITOR BATTERY

1. Remove the ignitor cover by turning it counterclockwise.



Important: Do not attempt to pull or turn the rubber cap.



2. Remove battery for replacement. The battery is reinstalled with the negative (-) end out.



3. After properly inserting the battery, replace the ignitor cover by turning the cap clockwise.



Note: If you have accidentally removed the rubber cap, follow the instructions below to replace it.

1. Pull the rubber cap and the inner plastic sleeve apart.
 2. Carefully insert the rubber cap into over and slide the plastic sleeve the ignitor cover so inner plastic sleeve it sits behind inner into the cap.
 3. Turn the cap lip.



TROUBLESHOOTING

If you have trouble with the unit, please use this list to identify the problem. By trying one or more of the solutions to the possible cause, you should be able to solve the problem. If this list does not cover your present problem, or if you have other technical difficulties with the unit, please contact your local dealer.

PROBLEM	POSSIBLE CAUSE	CORRECTION
Ignition system failure	1) Improper air shutter adjustment	1) Adjust air shutters.
	2) Ignition wire disconnected	2) Replug wires into generator.
	3) Low gas pressure	3) Have gas company check the operating pressure at the unit.
	4) Dead battery	4) Replace battery.
Insufficient heat	1) Improper air shutter adjustment	1) Adjust air shutters.
	2) Using propane orifice for natural gas	2) Change orifices.
	3) Low gas pressure/flame (natural)	3) Have gas company check the operating pressure at the unit.
	4) Low gas pressure/flame (propane)	4) Refill propane tank, or reset propane tank safety*: Shut off all valves (including propane tank) and follow lighting instructions exactly.
Uneven heating	1) Burner ports partially blocked by debris	1) Remove burners and clean out ports.
	2) Small spiders or insects in burner	2) Inspect burners for spider webs or other debris that may block gas flow.
Burner goes out on LOW	1) Valve "Low" setting needs adjustment	1) Light burner on HIGH, immediately turn to LOW setting. Remove knob from valve and using a small flat screwdriver, slowly turn the adjustment screw in the stem, a little at a time (30° to 45°), in either direction, until the flame is approximately 1/4" in height from burner ports.

Note: *Propane tanks are equipped with a safety shutdown device that may cause low or no gas/flame at the burners if operating and lighting instructions are not followed exactly. If you suspect the propane tank safety shutoff is in effect, shut off all burner control valves and the propane tank valve. Then read and follow the LIGHTING INSTRUCTIONS exactly. Lighting instructions are located in the owner's manual. If the problem persists, continue troubleshooting, or contact your local dealer or distributor for assistance.

AMERICAN OUTDOOR GRILL LIMITED WARRANTY

AMERICAN OUTDOOR GRILL LIMITED WARRANTY

American Outdoor Grill stainless steel burners are warranted for 15 YEARS
All other American Outdoor Grill parts are warranted for 10 YEARS

Except as noted below

American Outdoor Grill ignition systems (excluding batteries), accessories (including sideburners, motors, and thermometers), and flavor grids are warranted for one year from the date of purchase.

PLEASE KEEP A COPY OF YOUR SALES SLIP FOR PROOF OF PURCHASE

This warranty applies to the original purchaser and to single family residential use only. It commences from date of purchase, and is valid only with proof of purchase.

This warranty does not cover parts becoming defective through misuse, accidental damage, electrical damage, improper handling, lack of routine maintenance, storage, and/or installation. Product must be installed (and gas must be connected) as specified in the instructions or operator's manual, by a **qualified professional installer**. Accessories, parts, valves, remotes, etc., when used must be Peterson Co. product.

This warranty **does not** apply to rust, corrosion, oxidation, or discoloration, unless the affected component becomes inoperable. It **does not** cover labor or labor-related charges.

This warranty specifically excludes liability for **indirect, incidental**, or consequential damages. Some states do not allow the exclusion or limitation of incidental or consequential damages, so the above exclusion may not apply to you. This warranty gives you specified legal rights, and you may have other rights that may vary from state to state.

For additional information regarding this warranty, or to place a warranty claim, contact the R.H. Peterson dealer where the product was purchased.

**TO REGISTER YOUR PRODUCT ONLINE GO TO: WWW.AMERICANOUTDOORGRILL.COM,
AND CLICK ON PRODUCT REGISTRATION. THANK YOU FOR YOUR PURCHASE.**

American Outdoor Grills
14724 Proctor Ave.
City of Industry, CA 91746

Quality Check			Date: _____			
Burner Orifices	Nat.	L.P.	Leak Test:	_____	Model#:	_____
Main:	_____	_____	Burn Test:	_____	Serial#:	_____
Other:	_____	_____	Gas Type:	<u>Nat. / L.P.</u>	Air Shutter:	_____
					Inspector:	_____